

Truncated type flanged diaphragm seal

Model DF55

ASME B40.100

Features

- Welded diaphragm seal
- Variety of wetted parts material
- Filling port in the upper housing
- Suitable for pressure gauges, switches and transmitters
- Afford instrument protection from corrosives, heat and clogging issues associated with viscous media or solids

Size

2", 3" & 4" ASME/ANSI

Pressure Rating

150, 300 & 600 lbs

Applications

Chemical and petrochemical industry
Machine and apparatus construction
Corrosive processes
Elevated process temperatures



Technical specification	DF55
Process connection size, flanged ANSI	2", 3", 4"
Back up flange Rating ANSI	150 lbs, 300 lbs, 600lbs others on request
Construction	Machined flange with welded diaphragm via extension
Fill port	In upper housing side with stainless steel ball and set screw
Measuring principle	Diaphragm welded to flange
Instrument connections [female]	G ¼, G ½ female, ¼ NPT, ½ NPT female, Others on request
Sealing surfaces ANSI/ASME	B16.5 RF, optional RTJ
Material (wetted parts) Diaphragm & contact surface	Stainless steel 316L, Optional 316L with PTFE protection, Hasteloy-C276
Material (non wetted parts) Instrument connection Capillary and armor	Stainless steel 316L (1.4404) Stainless steel 316 and stainless steel 304
Filling liquids (temperature range)	Glycerin (0/400 °F, -18/204 °C), silicone (-40/600 °F, -40/315 °C), halocarbon (-70/300 °F, -56/149 °C), Syltherm 800 (-40/750 °F, -40/400 °C), vegetable oil (32/248 °F, 0/120 °C) Food grade silicone (-13/400 °F, -25/200 °C), Others on request, also depending on selected material and configuration.
Accuracy	Additional 0.5% to the specified tolerance of the mounted instrument
Mounting	Direct / Cooling Tower / with capillary
Weight dry in kg	Depending on flange size
Accessories, options	NACE, pressure gauges, pressure switches, transducers, capillaries

General dimensions in mm

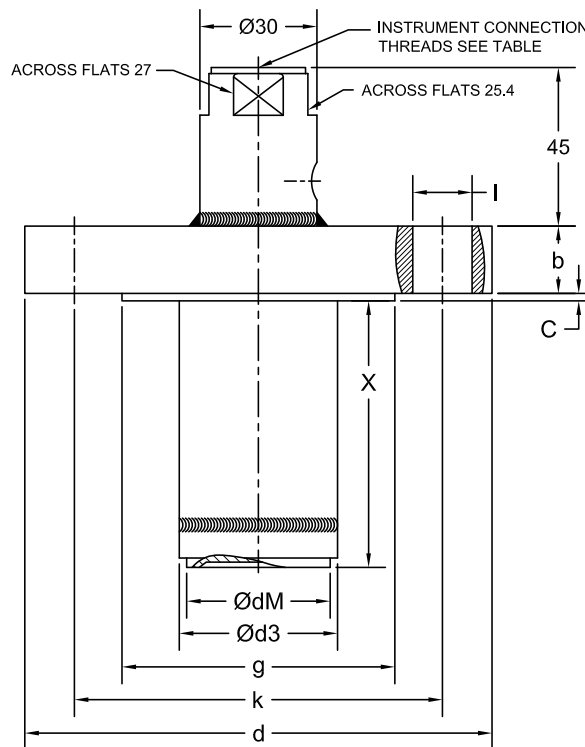

SIZE DN	ØdM	Ød3
2"	44	48.3
3"	57	76
4"	88	94

B, C, D, G, K, I AS PER ANSI B16.5, OTHER DIMENSION AVAILABLE ON REQUEST

Order information

Process Size	Type	Diaphragm	Flange & Extension material	Instrument connection	Flange Rating	Flange Facing	Extension	Filling fluid	Options
ANSI Flanged (20) 2" (30) 3" (40) 4"	DF55	(S) 316L (1.4404)	(S) 316	(02T) 1/4" NPT(F)	ANSI (150) 150 lbs (300) 300 lbs (600) 600 lbs	(RF) Raised face	(50) 50 mm ¹⁾	(CG) Glycerin (direct mounted, -18/204 °C)	(NH) Tagging wired
		(SJ) 316L with Teflon Coating ²⁾	(L) 316L	(04T) 1/2" NPT(F)		(FF) Flat face	(100) 100 mm ¹⁾	(CK) Silicone (direct mounted or with capillary, -40/315 °C)	(OF) Oil free (only filled with halocarbon)
		(H) Hastelloy C	(SJ) 316 with PTFE coating ²⁾	(13T) 1/4" BSP(F)		(RTJ) Ring joint type	(150) 150 mm ¹⁾	(CF) Halocarbon (direct mounted or with capillary, -56/149 °C)	(CA) Stainless steel armored capillary ³⁾
		(UG) 316L-Urea Grade (1.4435)	(H) Hastelloy C	(14T) 3/8 BSP(F)		(XX) customised dimension	(200) 200 mm ¹⁾	(CF) Halocarbon (direct mounted or with capillary, -56/149 °C)	(CP) Stainless steel armored capillary with PVC sleeving ³⁾
			(UG) 316L-Urea Grade (1.4435)	(15T) 1/2" BSP(F)			(XX) customised dimension	(HA) Syltherm 800 (direct mounted or with capillary, -40/400 °C)	
				others on request				(GZ) Vegetable oil (direct mounted or with capillary, 0/120 °C)	
								(CZ) Food grade silicone (direct mounted or with capillary, -25/200 °C)	
								others on request	

1) Other dimension on request

2) Restricted to temperature 200 °C

How to order

Process Size	Type	Diaphragm	Flange & Extension material	Instrument connection	Flange rating	Flange facing	Extension	Filling fluid	Options
20	DF55	S	S	14T	150	RF	100	CK	CA1.0

Precision Mass Products Pvt. Ltd.

Plot No.: 2306, G.I.D.C. Chhatral, Ta: Kalol, Dist.: Gandhinagar, Chhatral -382729, Gujarat, India.

Telephone: +91-2764 233681/82/83

Email: sales@precisionmass.com

Fax: +91-2764-233440

www.precisionmass.com

- North Zone : sales.delhi@precisionmass.com
- East zone : sales.kolkata@precisionmass.com
- West zone : sales.mumbai@precisionmass.com
- South zone : sales.chennai@precisionmass.com